

Compression plastic toy mould injection motor presser cap moulded

Mold Details:

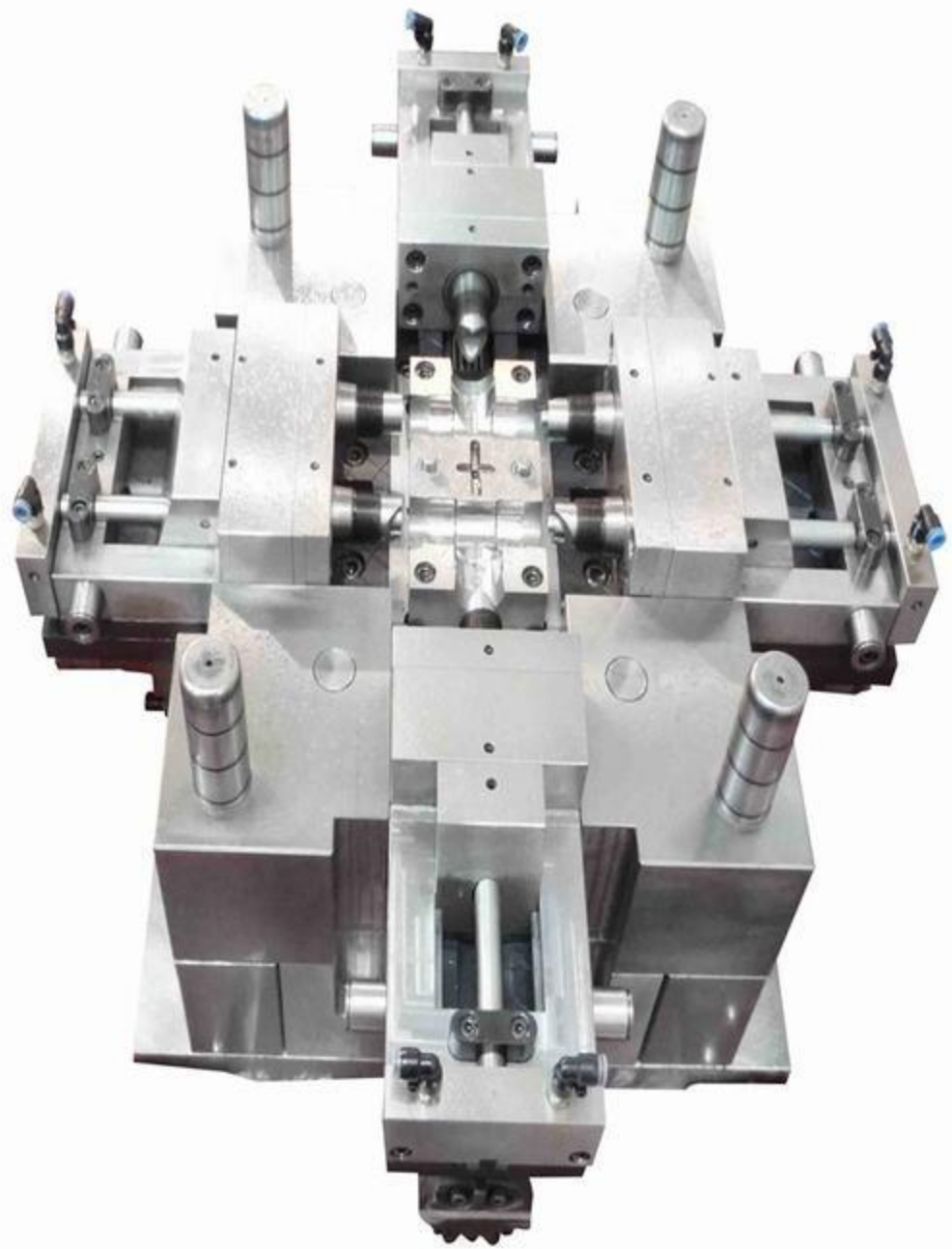

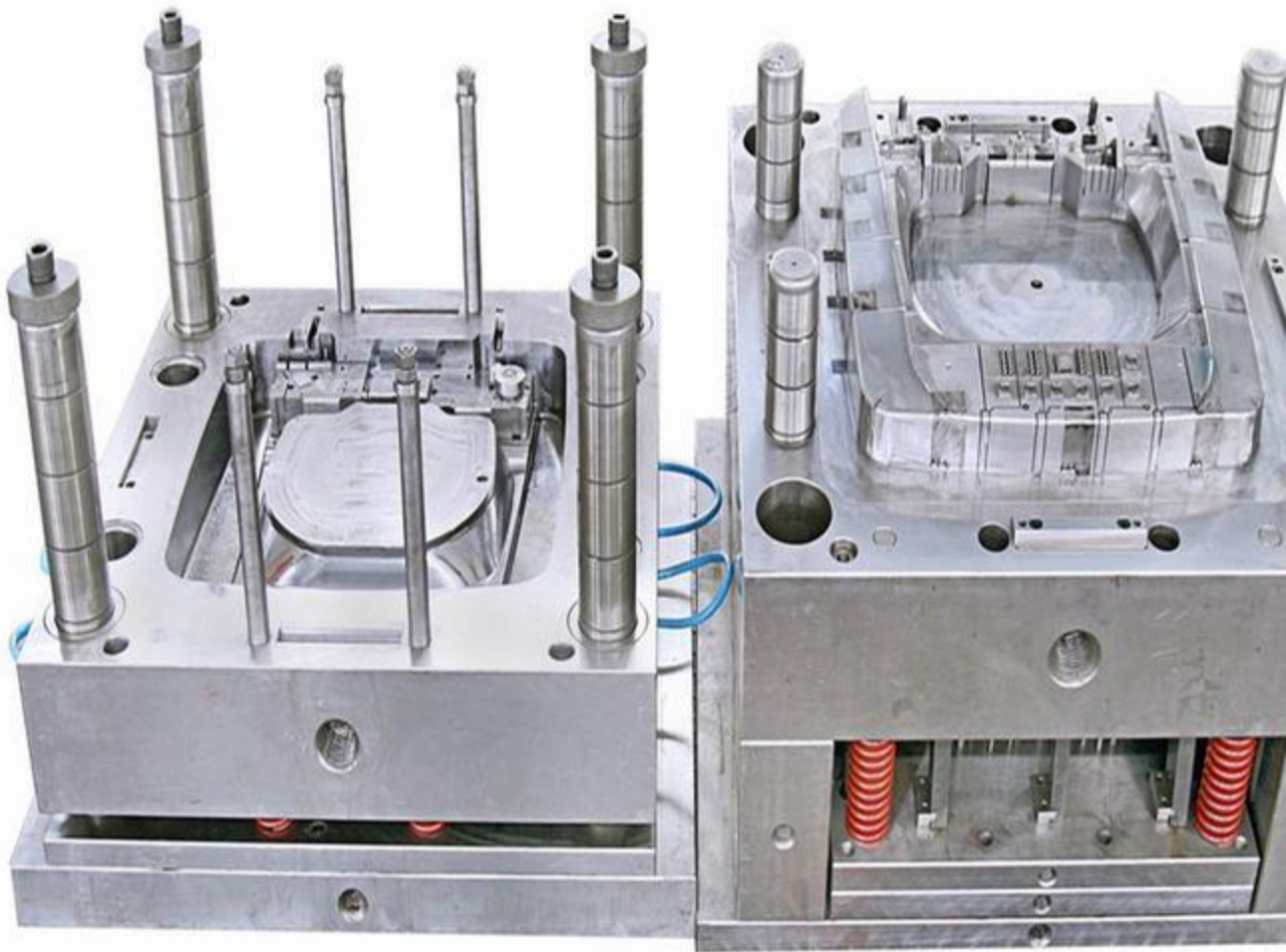



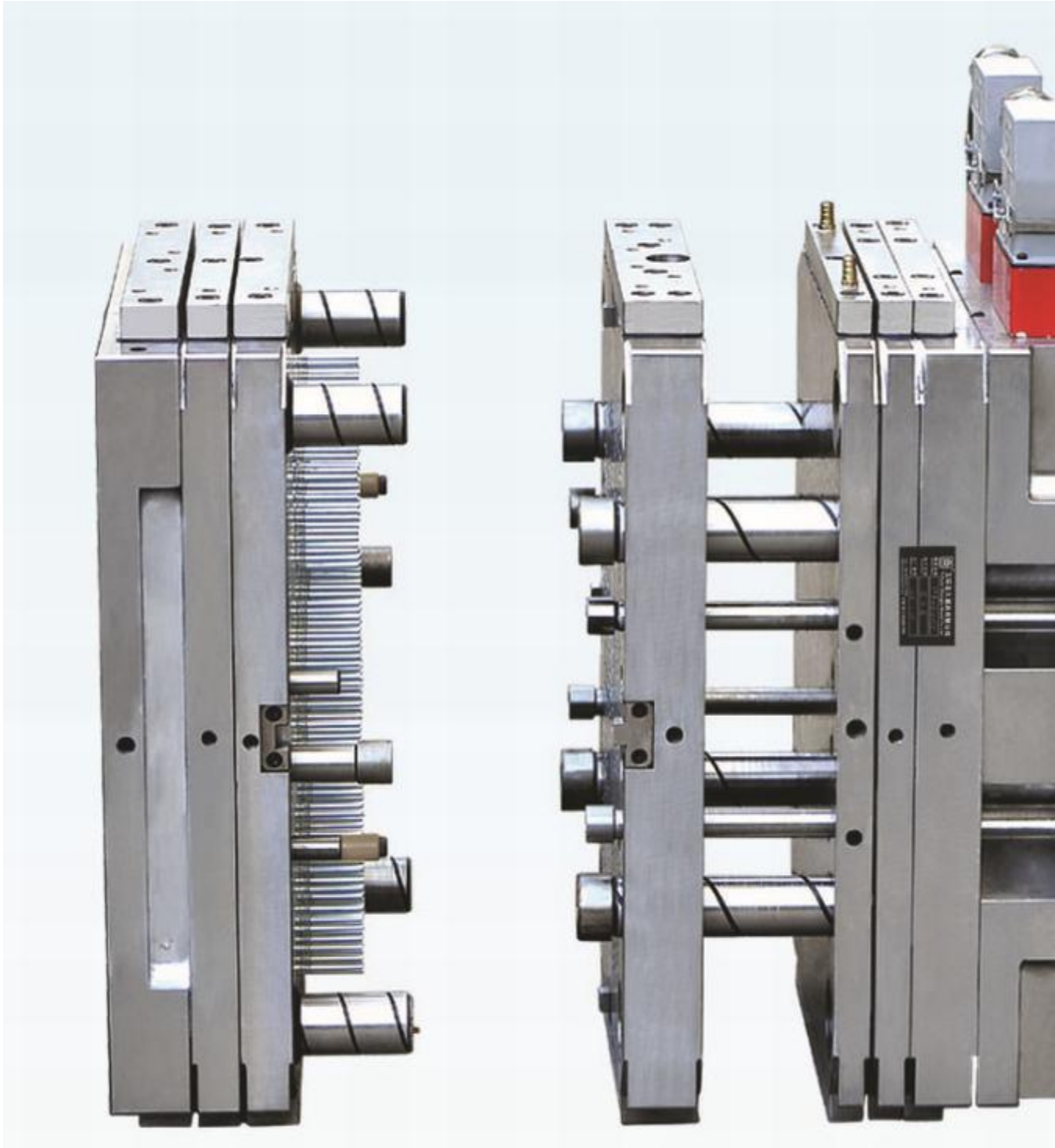

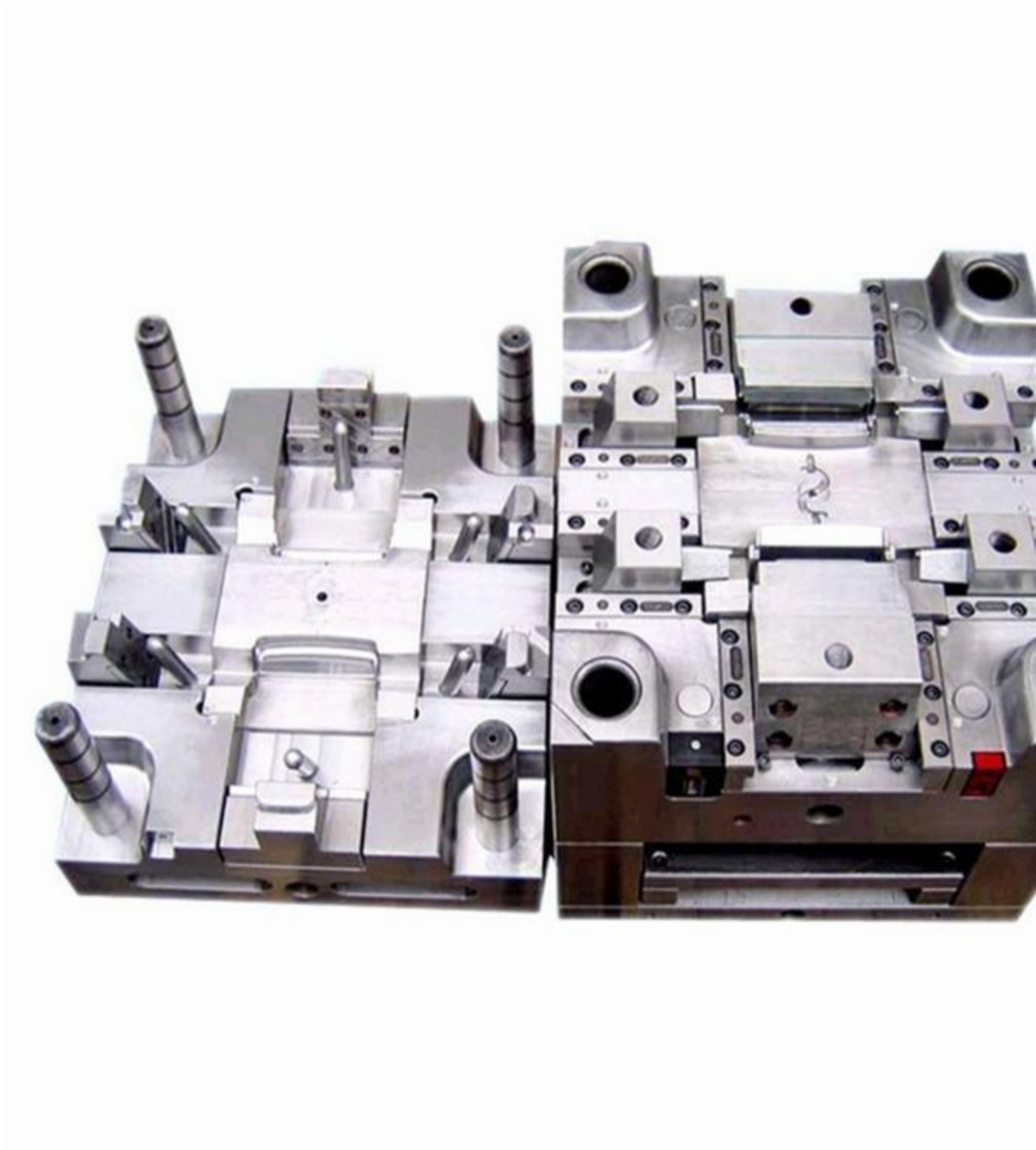

Place of Origin:Shenzhen, China (Mainland)

Brand Name:ABIS

Shaping Mode:Plastic Injection Mould

Product Material:ABS,PEM,PA,PS,ETC

Product: Auto part / Toy part

Product Color::White,Black,Red,Yellow,Blue etc.

Machine::CNC

CNC Machining Tolerance::0.003 to 0.005mm

Design software: STEP and X-T,UG,pro-E

Cavity:1 Cavity

Mold Life::50,000 to 1,000,000 shots

Mould Base:LKM,HASCO,DME

Runner:Hot/cold

Injection Mould running:Full automaticity

Injection Mould features:High classic very mature plastic
mould structure

Equipments: CNC, Electric Spark

Machine(WEDM-LS),Injection Machine

Mould Steel:NAK80,2738,2316,H13,718,S136,S136H ...

Mold making process:

ABIS WORKING PROCESS

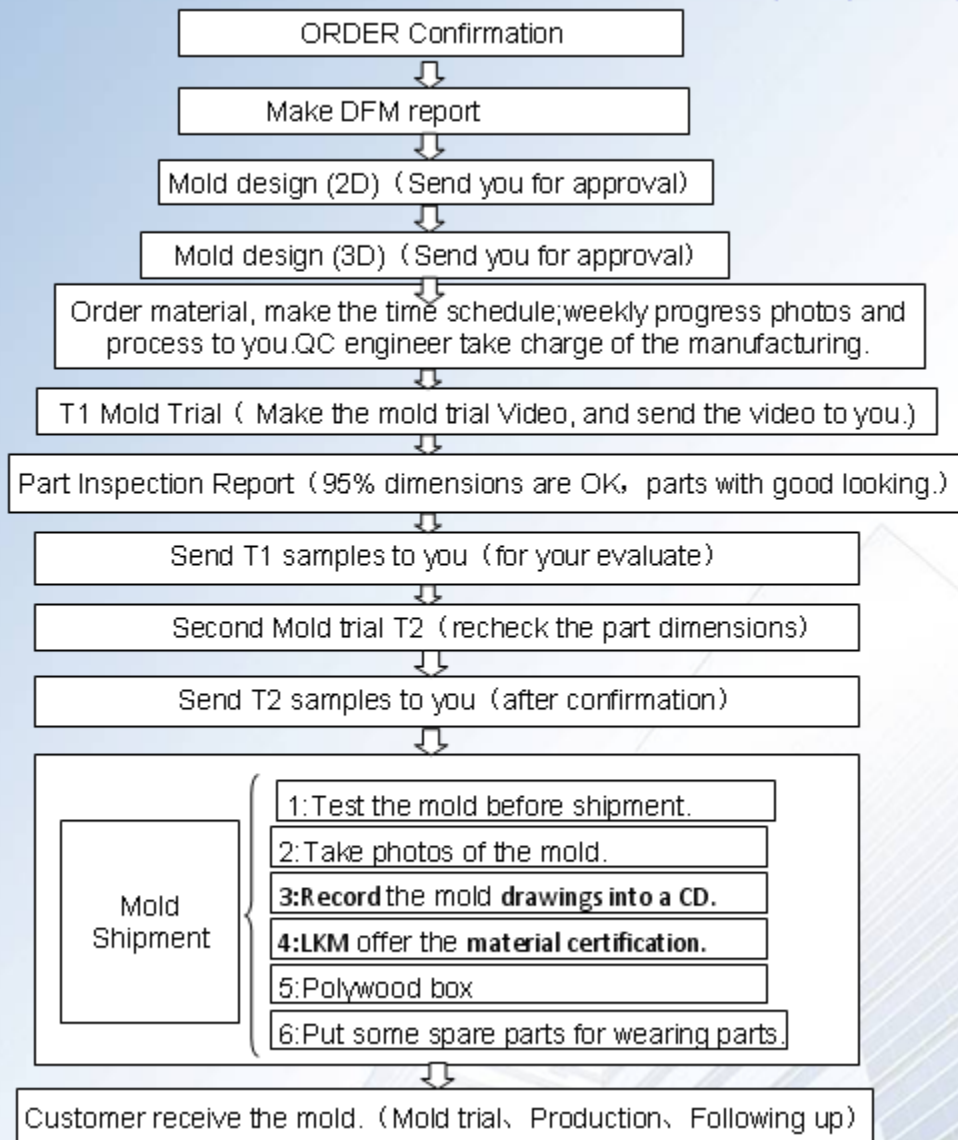

Company profile:

ABIS was founded in Shenzhen China, in 1996, adjacent to Hong Kong, has its own factory of 12,000 square meters. With the advanced facilities from Germany, Swiss and Japan, and a highly experienced design and engineering team.

Servicing various markets including Automotive & Aviation, Household & Industrial, Electronics & Telecommunications, Medical & Healthcare, OA equipment, Consumer Packaging, Personal care, and Sports, ABIS helps clients optimize productivity and minimize manufacturing costs, strengthening the ability of OEM to compete effectively on a global basis.

At ABIS, All new programs are entered into APQP as soon as the purchase order is received. A team will be assigned to review all steps of the project from tool design through work cell assignment, continuing on to the customer's first production run.

ABIS applies advanced software for mold design-Auto CAD, UG, Solid works and ProE etc. So far, ABIS has received the "ISO 9001" 、 TS16949 certificate.

Our molding press machine ranges from 40T to 650T, 200+ molds capacity each year, and 70 % are exported to Europe and North America. Post molding operations include; CNC Machining, decorating, ultrasonic welding, and assembly & insertion.

DME/HASCO/DIADO mold base from LKM, high grade steel such as ASSAB STAVAX S136, S-7, H13, NAK80 for Cavity/Core. Mold master / DME / HUSKY / Thermoplay / Incoe /YUDO HRS as specified. Mold components: DME, Progressive, PCS, Punch, Royal.

At ABIS, we understand that your projects deserve significant time and dedication to meet our highest standard of quality and commitment.







认证证书

此证书授予

深圳市艾比斯精密五金塑胶有限公司

认证地址：深圳市龙岗区龙岗街道龙东社区沙背坳福利工业园 C 栋一层

符合 ISO/TS 16949:2009 质量管理体系标准

认证范围：

塑胶制品（把手）的生产（不包括 7.3 产品设计）

注册号:	首次注册日期:	本次发证日期:
77463/A/0001/SM/ZH	2017 年 1 月 3 日	2017 年 1 月 3 日
组织机构代码:	注册有效期:	TATP No:
91440300553884491N	2018 年 9 月 14 日	02558925

发证人:  认证经理

本证书信息可在国家认证认可监督管理委员会官方网站 (www.cnrca.gov.cn) 上查询。
URS (中国) 地址: Room 805, 806, Block 3, Tianyi International Building
of Huzhou street No. 599 in Hangzhou City, Zhejiang Province of China. 电话: 0571-86700691



Certificate of Registration

This certificate has been awarded to

Shenzhen ABIS Precision Hardware Pla

Floor1, Building C, Sha Bei Li Ying Keli Industrial P
Community, Longgang Street, LongGang District, S
Guangdong Province, China

in recognition of the organization's Quality Management System

ISO/TS 16949:2009

The scope of activities covered by this certificate is def

Manufacture of Plastic Parts (Handles) (Excludes Pro
Clause 7.3)

Certificate Number:	Date of Issue of Certification Cycle:
77463/A/0001/SM/En	03 January 2017
Issue No:	Expiry Date:
1	14 September 2018

Issued by:  On behalf of the Sc





BEIJING HANGXIE CERTIFICATION CENTER CO.,LTD.
**QUALITY MANAGEMENT SYSTEM
CERTIFICATION**

ABIS MOLD TECHNOLOGY(HK)CO.,LTD

Organization Code: 55388449-1

No.102, Building B, Ying Keli Industry Area, Longgang District, Shenzhen, China. P.C 518116

is in conformity with

GB/T19001-2008 (ISO9001:2008)

This certificate is covering the following product scope

Plastic Mold Development and Manufacturing; Plastic Products Production

(Not Include the Products With Administrative Licensing)

Registration No. 03415Q20263ROM

The Duration of Validity :Feb . 10, 2015—Feb . 09, 2018



MANAGEMENT SYSTEM
CNAS C034-Q



General Manager: 

BEIJING HANGXIE
CERTIFICATION CENTER CO.,LTD.

After this certificate is issued, there should be at least 2 surveillance audits within the 3 year period of validity, the current validity of the certificate can be checked on (www.bhxcc.com.cn) The certificate information is available on the official website of the National Certification and Accreditation Administration (www.cnca.gov.cn) It is also available by scanning the two-dimensional code at the bottom right corner.



Detailed description of Custom Plastic Mould:

Cavity/Core Material	718H,P20,NAK80,2316,2738,DI N2344,H13 and available
Product Material	ABS,PC,PP,PVC,POM,PMMA,P S,PE,PET,RUBBER Silicone,P A,PBT,PEI,etc
Base	LKM or by requested
Structure	Double Color injection mold,So lid Mold,Insert Mold,Mold with Slide,Mold with Lifter
Runner System	Hot runner,Cold runner
Cavity	Single cavity,multi cavity by re quested
Finish	Corrosion word,Mirror finish,Bru shed
Mold standard	HASCO,DME,MISUMI, or by re quested etc
Software	STEP and X-T,UG,pro-E

Tolerance	+/-0.05mm
Design time	5-7 day
Sample time	1 week
Production time	3-5 weeks,depends on mold structure
Main technique	Milling,Grinding,EDM,Wire-cutting,Engraving,CNC etc
Longevity	0.5-1 million shots
Packing	Wooden case,PE,or by requested

Our products:

Electronic Products



Industrial Products



Household Products



Plastic Toy



ABIS Mould packaging :



Mold Parking



FAQ:

1) How can I place order?

A: You can contact us by email about your order details, or place order on line.

2) How can I pay you?

A: After you confirm our PI, we will request you to pay. T/T (HSBC bank) and Paypal, Western Union are the most usual ways we are using.

3) What's the order procedure?

A: First we discuss order details, production details by email or TM. Then we issue you an PI for your confirmation. You will be requested to do pre-paid full payment or deposit before we go into production. After we get the deposit, we start to process the order. We usually need 7-15days if we don't have the items in stock. Before production has been finished, we will contact you for shipment details, and the balance payment. After payment has been settled, we start to prepare the shipment for you.

4) How do you take care when your clients received defective products?

A: replacement. If there are some defective items, we usually credit to our customer or replace in next shipment.

5) How do you check all the goods in the production line?

A: We have spot inspection and finished product inspection. We check the goods when they go into next step production procedure.

